

Panasonic

No. : C-SB373H6B-00-GGS-0

APPROVAL SHEET SPECIFICATIONS OF HERMETIC SCROLL COMPRESSOR

CODE	809 851 86
MODEL	C-SB373H6B

△					
△					
△					
△					
△					
NO.	DATE	PAGE	REVISION DETAILS	PAPCDL SIGNED	CLIENT SIGNED

REVISION RECORD

USER:

MANUFACTURER:

Panasonic Appliances Compressor (Dalian) Co., Ltd.

LEADER	PURCHASING MANAGER	TECHNICAL MANAGER	APPROVED	CHECKED	SUBMITTED

Model: C-SB373H6B

File No: C-SB373H6B-00-GGS-0

Section 1. General Specifications

Content		Unit	Specification
Compressor Model (Code)		—	C-SB373H6B (809 851 86)
Type		—	Hermetic Scroll Compressor
Application		—	High Back Pressure
Evap. Temp. Range		°C (°F)	-15~12 (5~54)
Compressor Cooling Type		—	Natural Cooling
Power Source	Phase	—	3
	Rated Voltage	V	208-230
	Rated Frequency	Hz	60
Voltage Range		V	187-253
Weight (Including Oil)		kg (lb)	38.0(83.8)
Refrigerant		—	R22
Oil Type		—	Mineral Oil(SAY56T or Equivalent)
Oil Charge		ml (fl oz)	1700 (57.5)
Displacement		cm ³ (in ³) /rev	83.2(5.08)
Motor	Motor Type	—	3-PH Induction Motor
	Number of Poles	—	2
	Electrical Insulation	Class	E
	Nominal Revolution	min ⁻¹	3490
	Locked Rotor Ampere	A	134
	Winding Resistance [at 25°C (77°F)]	Ω	U-V
U-W			0.572
V-W			0.542
Connection Tube	Suction Line (O.D.)	mm (in)	22.2 (0.875)
	Discharge Line (O.D.)	mm (in)	12.7 (0.500)
Compressor Surface Paint		—	Black Paint

Notes

- 1 Voltage range is applied at standard rating conditions.
- 2 Motor specifications in the table are the average values for your reference.
- 3 (): All units with parentheses are reference values.

Expiration of Specification

Expiration of this specification shall be effected until issuing a notice with indication of the expiration date from the issued date . In case of improvement or elimination of this specification , it shall be handled by the revision record based on agreement between both sides.

Model: C-SB373H6B
File No: C-SB373H6B-00-GGS-0

Section 2. Performance Warranty

2.1 Performance

Power Source (3PH)	Hz	60	60	Remark
	V	208	230	
Capacity	W	18,100	18,100	±5%
	(BTU/hr)	61,757	61,757	reference
Input Power	W	5,450	5,550	±5%
Current	A	17.30	17.50	±5%

Standard Rating Conditions

Condensing Temp.	°C (°F)	54.4(130)
Evaporating Temp.	°C (°F)	7.2(45)
Suction Gas Temp.	°C (°F)	18.3(65)
Liquid Temp.	°C (°F)	46.1(115)
Ambient Temp.	°C (°F)	35.0(95)

2.2 Sound Level

Power Source (3PH)	Hz	60
	V	230
Sound Level	dB(A)	65.0Max.

Notes

- 1 The operating conditions are the same as 2.1.
- 2 MIC location is the distance of 1m (3.28feet) from the compressor.
- 3 Sound Level is an average sound pressure level in four directions.

2.3 Minimum Starting Voltage

Power Source (3PH)	Hz	60
Minimum Starting Voltage	V	166

Conditions

Compressor Temp.	°C (°F)	10~60(50~140)
Ambient Temp.	°C (°F)	10~40(50~105)
High Pressure	MPa(G)/psig	2.0(290)
Low Pressure	MPa(G)/psig	0.5(72)

2.4 Others

Content	Unit	Specification
Design Pressure	L.P. S.	MPa(G)/psig
	H. P. S.	MPa(G)/psig
Insulation Resistance	MΩ	100 (without refrigerant)
Dielectric Strength	V	1800 (1 second)
Residual Moisture	mg	300

Note:

1. The insulation resistance be measured with a DC500V megohm tester.

Model: C-SB373H6B

File No: C-SB373H6B-00-GGS-0

Section 3. Standard Accessories

3.1 Accessories List

Parts Name	Qty	Parts code	Revision No.	Note
Terminal Box Cover	1	A-0101-DSB	0	Installed on Compressor
Terminal Box Clip	1	A-0201-DSB	0	Installed on Compressor
Eyelet Rub Lead Wire	1	A-0301-DSB	0	Installed on Compressor
Mounting Grommet	4	M-0101-DSB	0	Included with Compressor
Mounting Sleeve	4	M-0201-DSB	0	Included with Compressor
Screw Special	1	B-0101-DSB	0	Installed on Compressor

3.2 The Drawing for Reference

Parts Name	Parts Code	Revision No.
Compressor Outline Drawing	D-0101-DSB	0
Mounting Parts Listing	M-5101-DSB	0
Packing Dimensions	D-0202-DSB	0
Wiring Diagram	E-0914-DSB	0

3.3 Internal Motor Protector (in compressor)

Parts Name	Specification	
Internal Motor Protector	Trip Temperature	130±5℃
	Reset Temperature	70±10℃
	Trip Current	105A / 3~10s

Section 4. Compressor Protection

4.1 Protection Required but not Included with compressor

Protection Device	Items	Specifications
Reversal Defensible Relay	Features	To protect the compressor from reverse rotation
	Rated Voltage	AC208-230V
Crankcase Heater	Rated Power	35 Watts
Discharge Thermostat	Mounting Position	Located within 100mm(4 in)from the compressor shell
	Trip Temperature	130±5°C(266 ±10 °F)
	Reset Temperature	95±11°C (205 ± 20 °F)
High Pressure Switch	Setting	Cut-out seting no higher than 3.0MPa(G)
Low Pressure Switch	Setting	Cut-out seting no lower than 0.03MPa(G)

4.2 Position of the Protection and Refrigerant Charging

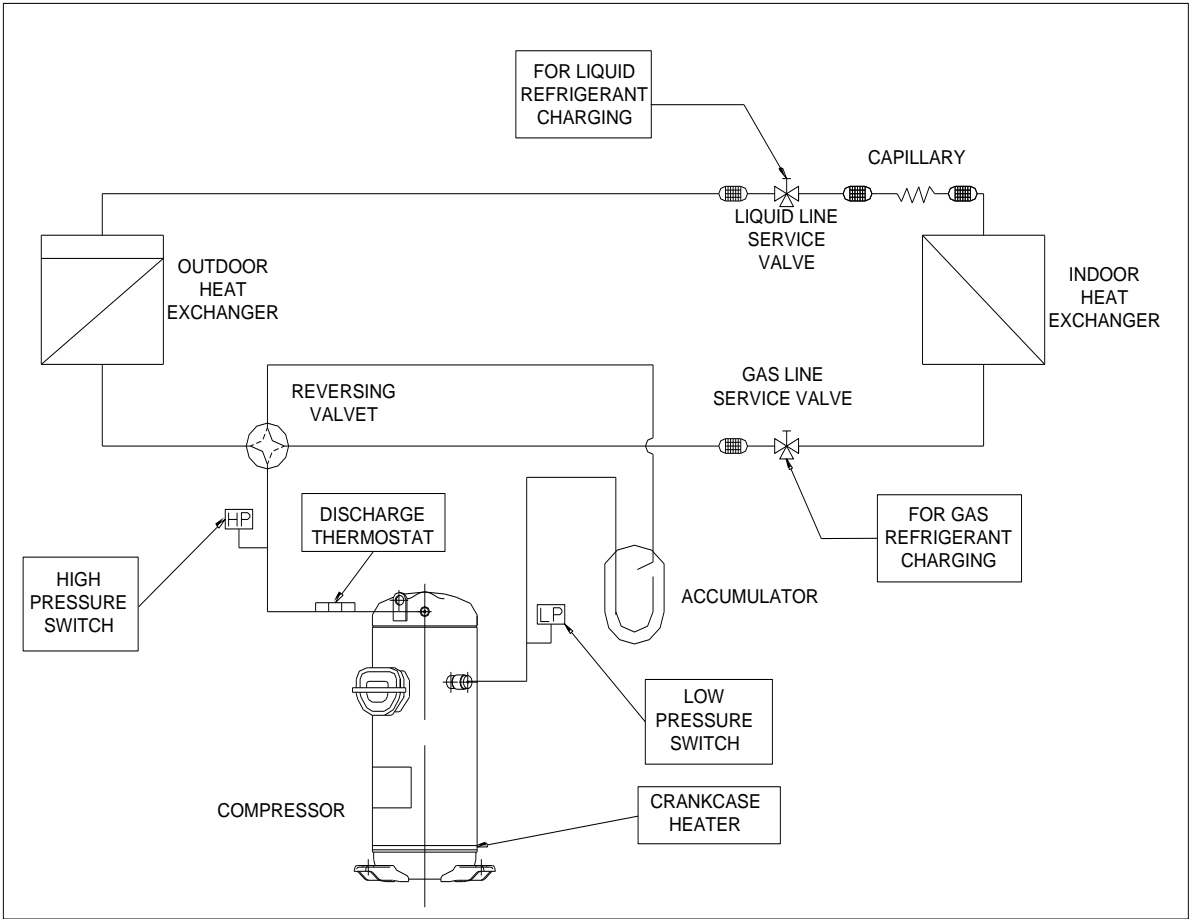

Section 5. Operating Envelope

Suction Gas Superheat: 11.1K

Refrigerant: R22

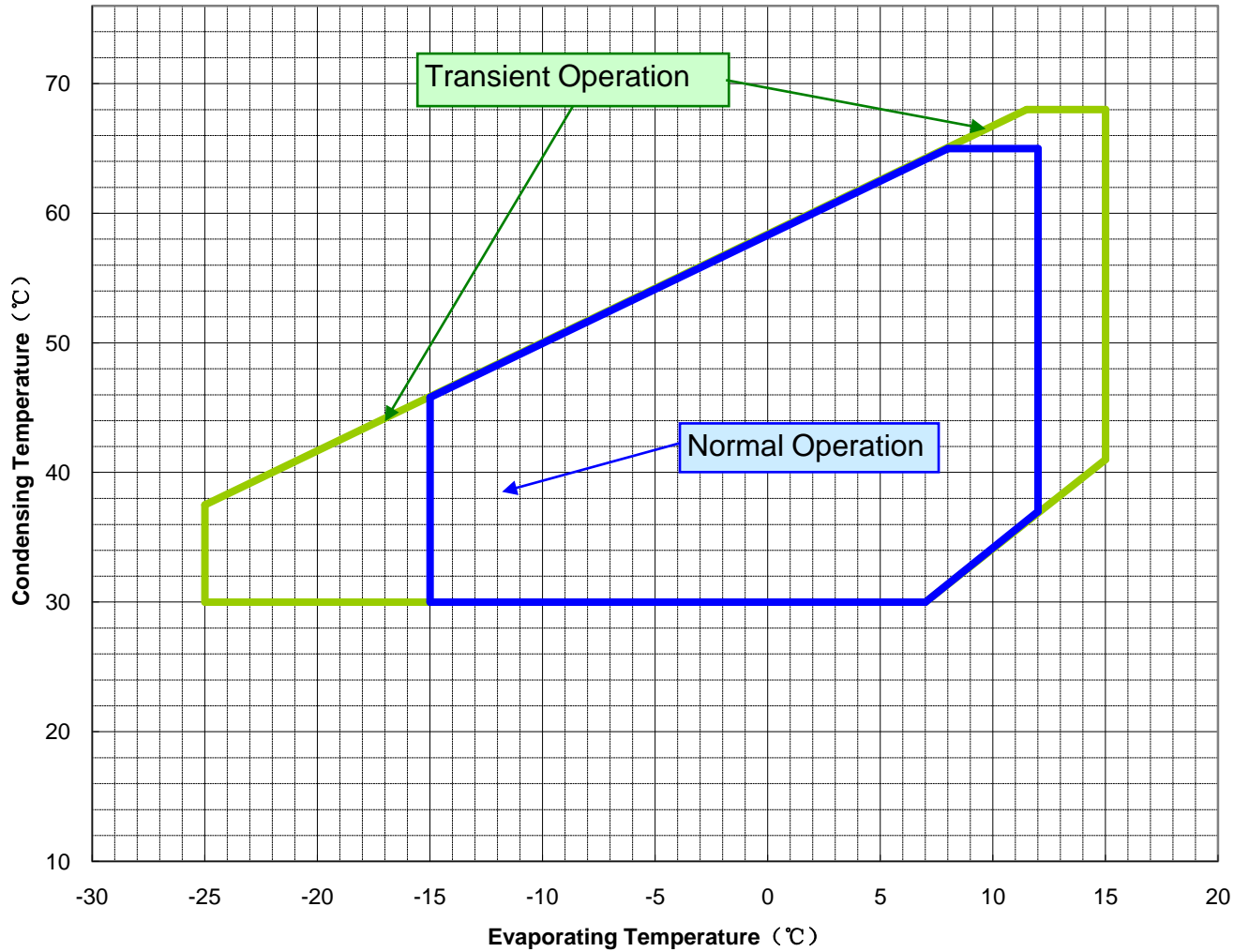

Section 6. Application Standard & Limit

The following requirements apply to vertical type hermetic scroll compressors:

Standard: Applicable to ordinary conditions in Japan JIS B8616 or standards relative to JIS B8616, such as standard rating conditions, maximum operating conditions, low temperature conditions, etc.

Limit: Applicable to transitional brief period of time, such as start-up and beginning of defrost mode.

No.	Item	Standard	Limit	Note
1	Refrigerant	R22(Meet the standard of Japan JIS K1517)		
2	Evaporating Temp.	-15~12°C(5~54 ° F) 0.20~0.62MPa(G)(29~90psig)	-25~15°C(-13~59 ° F) 0.10~0.69MPa(G)(14.5~100psig)	Comp. Suction Pressure
3	Condensing Temp.	30~65°C(86~149 ° F) 1.09~2.60MPa(G)(158~377psig)	68°C(155 ° F) 2.78MPa(G)(403psig)	Comp.Design Pressure(High) 3.0MPa(G) (435psig)
4	Compression Ratio	2 ~ 6	10	
5	Winding Temp.	115°C(240 °F) Max.	125°C(257 °F)	
6	Shell Bottom Temp.	90°C(194 °F) Max.		
		Evaporating Temp.+12°C(21 °F) Min.		Operating
		Ambient Temp.+11°C(20 °F) Min.		Not Operating
7	Discharge Gas Temp.	115°C(240 °F) Max.	C-SB:130°C(266°F) Max.	Temp. within 100mm(4in) of the discharge fitting.
			C-SC:135°C(275°F) Max.	Temp. inside of the well pipe on the top of compressor
8	Suction Gas Temp.	Superheat: 5K(10 °F)Min.	No excessive noise	It should meet the requirement of item 5, 6, 7 and 14 within 30cm of the suction fitting.
9	Running Voltage	Within ±10% of the rated voltage		Voltage at compressor terminals.
10	Starting Voltage	Three Phase Models: 85% of the rated voltage min.		Voltage at compressor terminals.
		Single Phase Models: 90% of the rated voltage min.		
11	On/Off Cycling	On Period: Until the oil level returns to the center of the lower bearing Off Period: Until balance of high and low pressure is obtained		For at least 7 minutes - on/3 minutes-off is recommendable.
12	Refrigerant Charge	oil/refrigerant(wt.)≥0.35		Specific gravity of the Oil:0.92.
13	Life Time	200,000 cycle		
14	Minimum Oil Level	C-SB: Center of the lower bearing	C-SB:Bottom of the lower bearing	
		C-SC:No less than 70% of the initial oil charge		
15	Abnormal Pressure Rise/Drop	Pressure Rise: 3.0MPa(G) (435psig) Max.		By high pressure switch
		Pressure Drop: 0.03MPa(G) (4.35psig) Min.		By low pressure switch
16	System Moisture Level	200ppm Max.		
17	System Uncondensable Gas Level	1 Vol.% Max. Residual Oxygen 0.1 Vol.% Max.		24 hrs. after vacuuming: 1.01kPa Max.
18	Tilt	5° Deg.Max.		

Operation beyond the above limits must be approved by Panasonic Appliances Compressor (Dalian) Co., Ltd.

(G): Gauge Pressure

Notes

- 1 Installation should be completed within 15 minutes after removing the rubber plugs.
- 2 Do not use the compressor to compress air.
- 3 Do not energize the compressor under vacuumed condition.
- 4 Evacuation and Refrigerant charge : Evacuate internal section in the refrigeration system from high and low pressure sides and charge liquid refrigerant from condenser outlet side. Additional charge shall be done with gas condition from low side.
- 5 Do not tilt over the compressor while carrying it.
- 6 Do not remove the paint.
- 7 Crankcase heater is required when the oil sump temperature is too low to meet the requirement of item 6 on page 7.
- 8 Voltage fluctuation between compressor terminals, during operation, shall be within 2% of the rated voltage.
- 9 Do not operate compressor in reverse rotational direction.
- 10 Suction strainers are recommended for all applications.
- 11 Copper Piping Stress

Start/Shutdown	34.32 N/mm ² Max.
Run	12.26 N/mm ² Max.

Section 7. Selection of Electrical Wire

Voltage drop may occur due to the large current draw during compressor starting.

We recommend selecting the wire size from the table below.

7.1 Type of Unit

7.1.1 Window & Commercial Type Unit

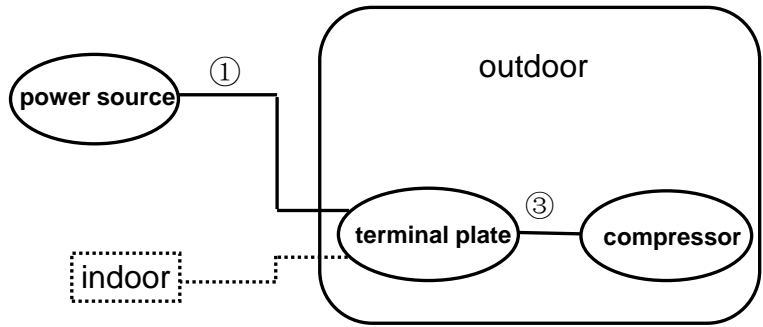

7.1.2 Split Type(Separate Type)

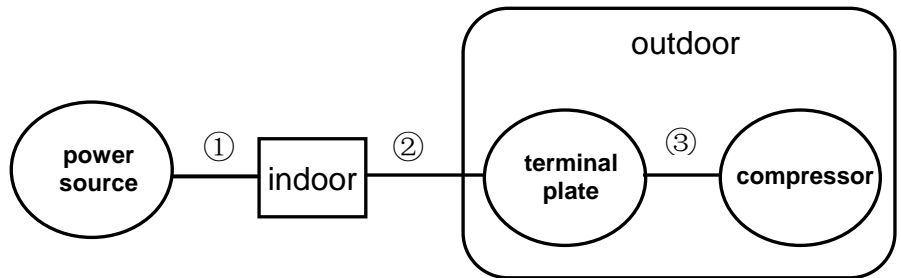

7.2 Size Table of Electrical Wire

Starting current (A)	Size of electrical wire (mm ²)						
	Remark ① or Remark ①+② (heat-resistance Temperature: 60°C(140°F) min.)						Remark③ (heat-resistance Temperature: 120°C(248°F) min.)
	5m max.	10m max.	15m max.	20m max.	30m max.	50m max.	1m max.
20max.	2.0	2.0	2.0	3.5	5.5	8.0	2.0
30max.	↑	↑	3.5	5.5	↑	14.0	↑
40max.	↑	3.5	5.5	↑	8.0	↑	↑
50max.	↑	↑	↑	8.0	14.0	22.0	↑
60max.	↑	5.5	↑	↑	↑	↑	↑
70max.	3.5	↑	8.0	14.0	↑	↑	3.5
80max.	↑	↑	↑	↑	22.0	30.0	↑
90max.	↑	↑	14.0	↑	↑	↑	↑
100max.	↑	8.0	↑	↑	↑	38.0	↑
110max.	↑	↑	↑	↑	↑	↑	↑
120max.	5.5	↑	↑	22.0	30.0	↑	↑
140max.	↑	14.0	↑	↑	↑	50.0	5.5
160max.	↑	↑	22.0	↑	↑	↑	↑
180max.	↑	↑	↑	↑	38.0	60.0	8.0
200max.	8.0	↑	↑	30.0	↑	↑	↑
220max.	↑	↑	↑	↑	50.0	80.0	↑
240max.	↑	↑	↑	↑	↑	↑	14.0

7.3 Caution of Ground

The internal motor protector does not protect the compressor against all possible conditions.

Please be sure that the system utilizes the ground connection when installed in the field.

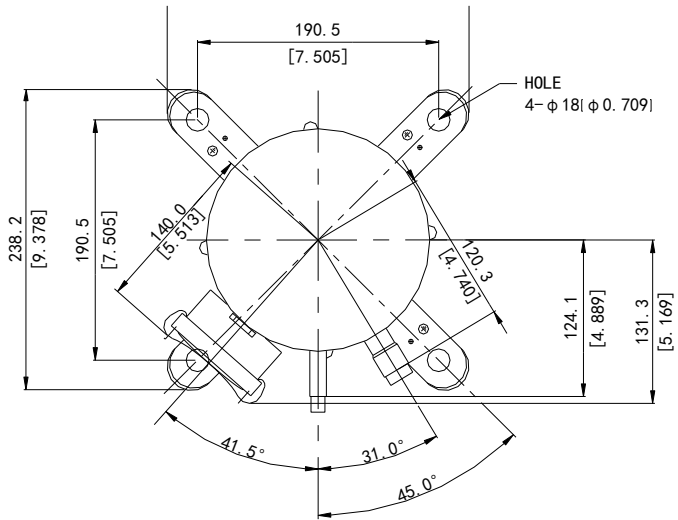

No.	Part Code	Qty	Name
1	809 851 86	1	Compressor
2	A-0101-DSB	1	Terminal Box Cover
3	A-0201-DSB	1	Terminal Box Clip
4	A-0301-DSB	1	Eyelet Rub Lead Wire
5		1	Nameplate
6	B-0101-DSB	1	Screw Special

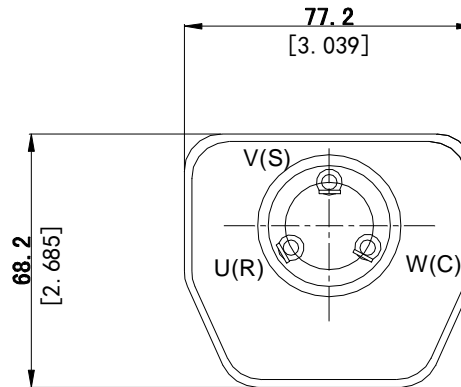
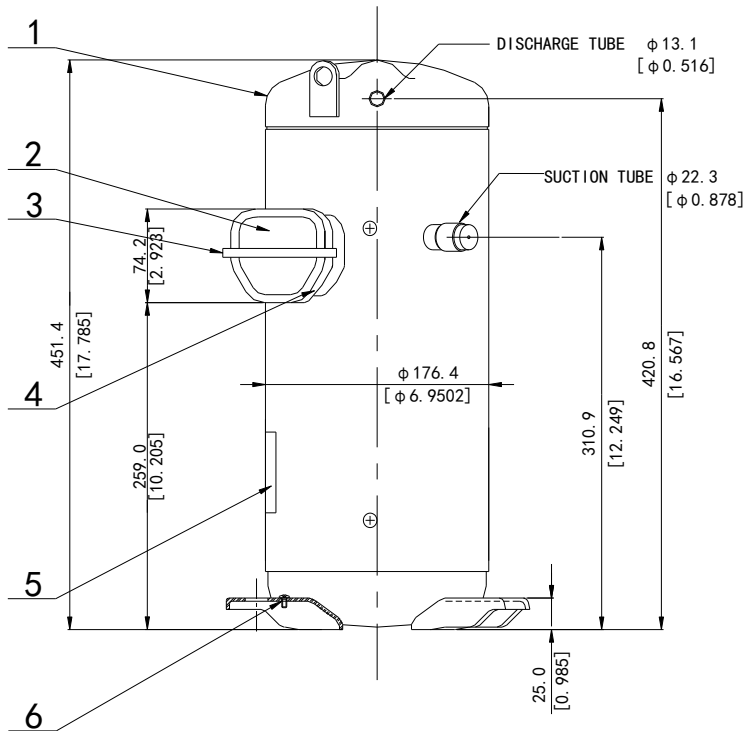

TERMINAL

Part Code
D-0101-DSB
Name
Compressor Outline Drawing

No.	Part	QTY	Name
1	M-0101-DSB	4	Mounting Grommet
2	M-0201-DSB	4	Mounting Sleeve
3	B-0101-DSB	1	Screw Special

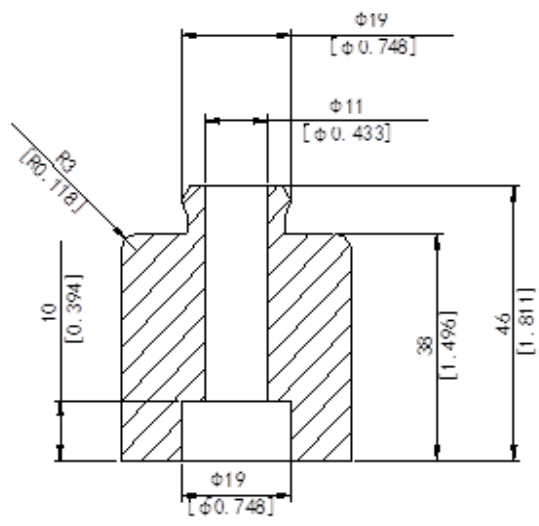
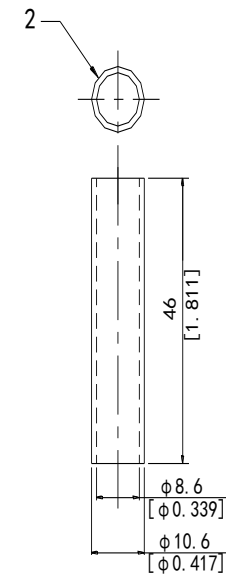
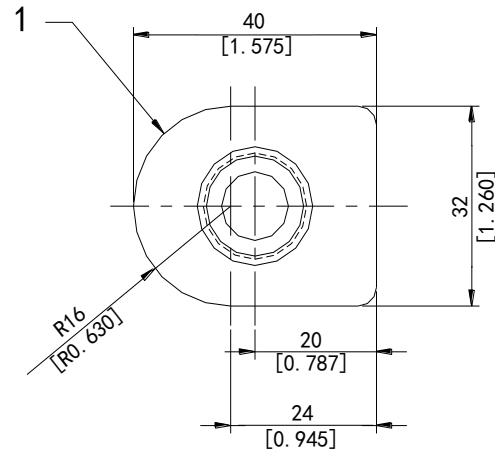
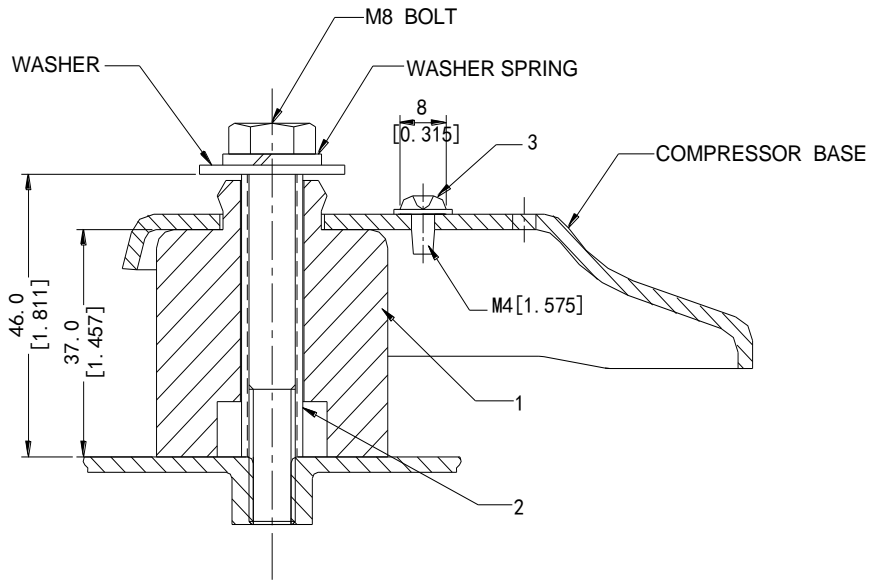

Part Code
M-5101-DSB
Name
Mounting Parts Listing

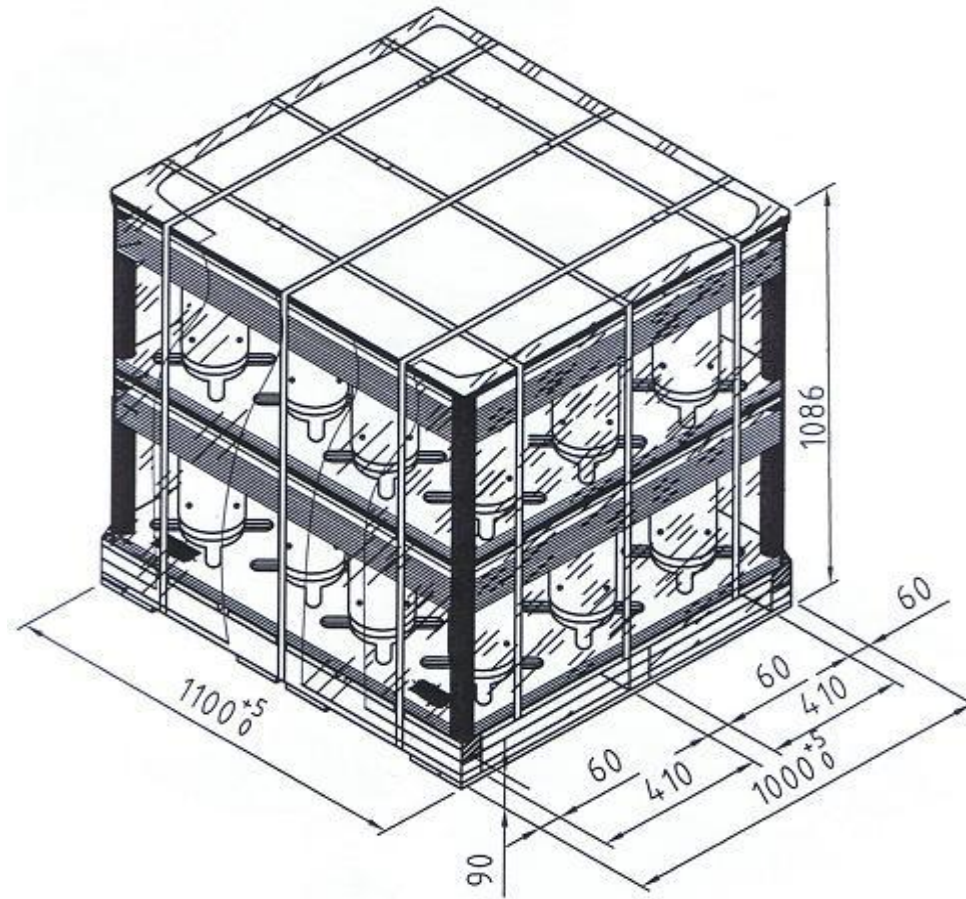

Part Code
D-0202-DSB
Name
Packing Dimensions

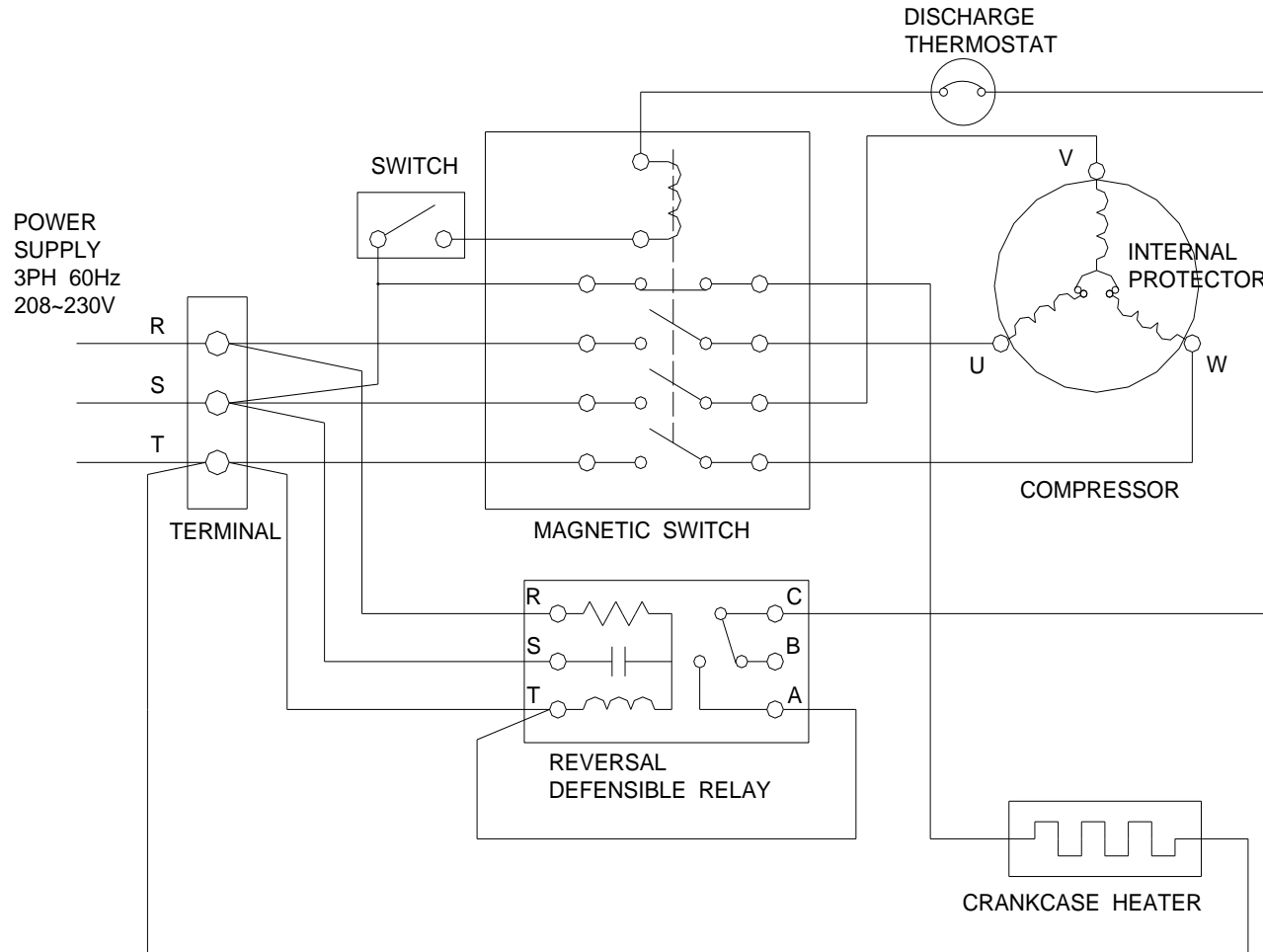

Part Code
E-0914-DSB
Name
Wiring Diagram